

CONTROLEDGE™ HC900

Process Control and Safety Made Easy

Process Measurement
and Control



Diverse Applications Ranging from Process PLCs to DCS

The Honeywell ControlEdge™ HC900 Process and Safety System is a fully field-proven system for process control and safety applications, with over 13,000 installations throughout the world. Its SIL-2 certification means it can be used in a variety of safety application such as burner management systems (BMS), emergency shutdown systems (ESD), fire & gas monitoring, pipeline monitoring, spill prevention etc.

TUV Compliance

The ControlEdge HC900 is fully validated to perform its safety tasks, and is certified by TUV for use in a SIL-2 environment. The system is ideal for a process/safety environment.

Its non-interfering software means that the ControlEdge HC900 system is capable of hosting process control and safety applications, providing control, monitoring, password

protection for configuration, alarm processing and data acquisition for process applications thus adding to reliable data and information being stored and protected.



Typical Industries

- Chemicals (including specialty and fine chemicals, plastics and rubber)
- Pharmaceuticals and Cosmetics
- Power (excluding nuclear)
- Cement and Glass
- Pulp and Paper
- Mining and Metals
- Water and Waste Water
- Food and Beverage
- Heat Treatment
- Buildings/
Infrastructure- Metro Rail, HVAC etc.

Customer Benefits

Proven & Reliable

Maximizes uptime

- Proven track record
- Redundancy
- G3 conformal coating for harsh environment
- RoHS compliant
- Actionable information

High Performance

Increases profitability

- Tighter control
- Reduced scrap
- Higher throughput

Easy to Use & Engineer

Lowers operational costs

- Easy engineering
- Faster startup
- Simple intuitive tools
- No additional maintenance fees

Enhanced Safety

with SIL2 certification

- Common hardware and software for process and safety
- Improved plant safety

Typical Applications

Safety

- Burner Management Systems (e.g. furnaces, boilers, ovens, pre-heaters, reactors, calciners, dryers, thermal oxidizers, kilns, melters, incinerators, process heaters, vaporizers)
- Combustion Control
- Pipeline Monitoring
- Spill Prevention
- Metro/ Road Transportation- Tunnel Safety, Ventilation
- Waste Water Treatment
- Terminal Automation
- Emergency Shutdown
- Fire & Gas Monitoring
- Pressure and Flow Control

Critical Control

- Electronics & SemiConductor
- Cement and Glass
- Textiles

Certifications

- TUV SIL2
- CSA-Canada and USA (HazLoc) / FM CL1 / Div2
- ATEX
- ABS
- UL
- CE
- RoHS



Multiple Systems, Multiple I/O Racks

ControlEdge HC900 Hot Stand-by Architecture

Experion HS / LX Server with
 - Redundancy
 - Station
 - Engineering Tools

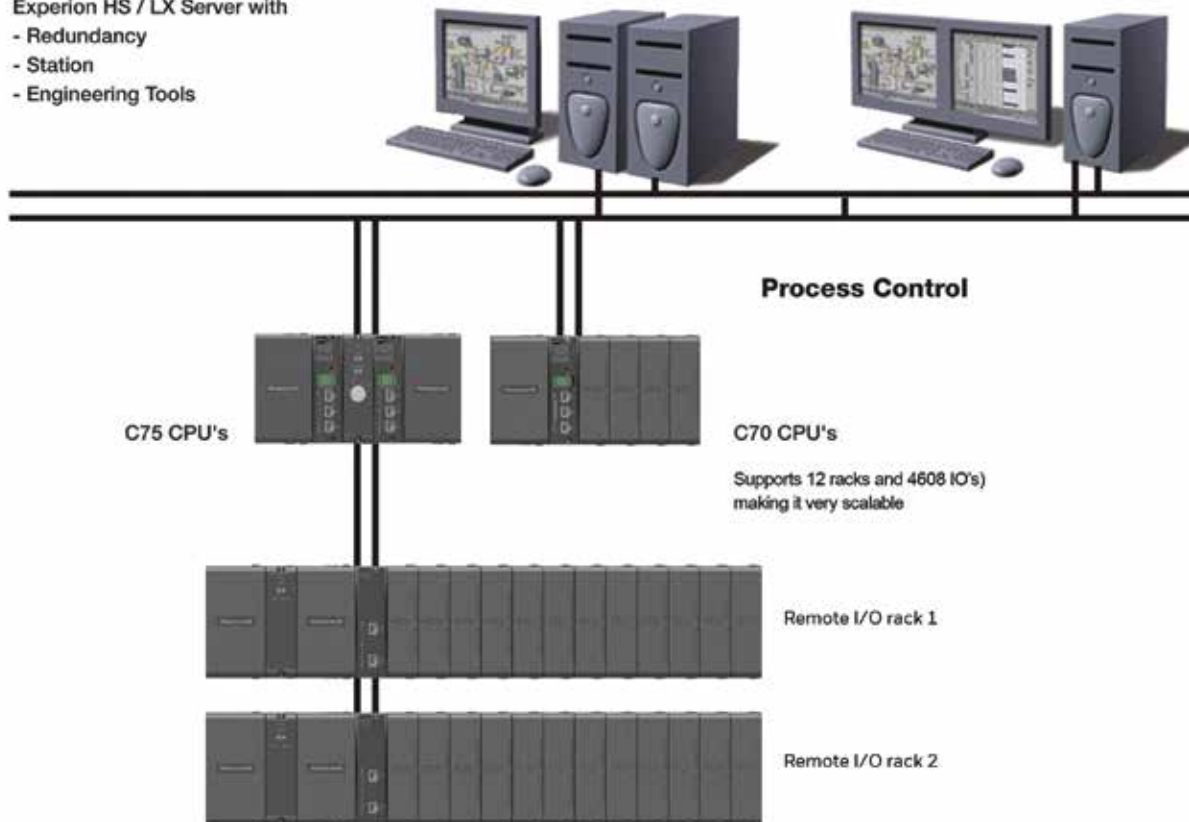

CPU Capacity

Function	Point per module	Max. for C30 CPU	Max. for C50 CPU	Max. for C70 / C75 CPU
Analog in	Universal: 8, High Level: 16	Universal: 96, High Level: 192	Universal: 1152, High Level: 2304	Universal: 1152, High Level: 2304
Analog out	4, 8, 16	40	480	480
Analog out (external Power)	8, 16	192	2304	2304
Digital in	16 or 32	384	4608	4608
Digital out	8 AC or 16 DC, 32	384	4608	4608
Function blocks	n/a	400	2000	15000

Experion Station
eServer



900 Control Station

Dual Ethernet

Safety Systems



C75S (dual networks)



Remote I/O rack 1



Remote I/O rack 2

Controller

- Function Blocks: C70, C75 CPU-15000, C50 CPU-2000, C30 CPU-400
- Analog Inputs: Up to 1152 universal analog inputs, 2304 high level, A/D Resolution is ± 15 Bits
- Accuracy: 0.1% of span (field calibration to $\pm 0.05\%$ of span)
- Analog Outputs: Up to 480 with internal power, 2304 with external power 0 to 20 mA maximum, 0.1% accuracy
- Universal SIL IO Module (UIO)- 16 channel, with 1ms SOE, Line Monitoring, Voting & Validation
- Digital Inputs / Outputs: Up to 4608, contact DI, 24 Vdc DI / DO, 120VacDI / DO, 240 Vac DI / DO
- Total I/O: Up to 4608
- I/O Racks per System: One controller and up to 11 remote I/O racks
- Control Loops: PID, on/off, cascade, ratio, %C, three-position step
- Control Output Types: Current, time -proportioning, position-proportioning, three-position steps
- New Input Voting (1oo2 and 2oo3) and output validation function blocks (with feedback verification)
- Setpoint Programmers: 50 segments each, 16 event outputs, multiple stored profiles
- Setpoint Scheduler: 50 segments, 8 ramp / soak outputs, eight auxiliary outputs, 16 events, multiple schedules
- Communications: Ethernet 10 / 100 / base T, Modbus / TCP protocol, up to 10 Ethernet hosts on C50, C70, C75 up to 32 peer-to-peer controllers, Serial Modbus RTU, RS485, slave or master operation (up to 32 slaves)
- Operating Temp: Rated 32° to 140°F (0° to 60°C)
- Humidity: Rated 10% RH to 90% RH, non-condensing

ControlEdge HC900 Designer Software

- Configuration: ControlEdge HC900 Controller – offline with run-mode editing
- Operating environment: Windows 7 Pro (32 or 64-Bit), Win 8 and Win 10
- PC: Pentium, 1.5 GHz with 1 GB RAM minimum, SVGA or greater screen resolution
- English and Mandarin languages supported (switchable after installation)
- Cable: RS 485 – three-wire, Ethernet 10/100 base T
- Modem support: Monitor, upload, download configuration
- New input voting (1oo2 and 2oo3) and output validation function blocks (with feedback verification)
- New non-interfering process and safety worksheets in
- Change management and Version Control built into the software same configuration



Modular and Scalable

- Available in three rack sizes and three CPU performance levels
- Scalable and expandable
- Handles a wide range of automation requirements
- Easy to own, engineer, operate and maintain
- Analog and digital modules support up to 4608 I/O points
- Upto 12 racks and 4608 IO's



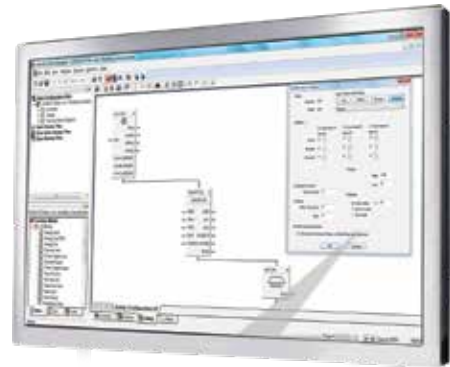

Function Blocks

- Simplify execution of complex control strategies
- Over 125 different types of software function blocks available
- Each function block represents a unique algorithm for a specific control function
- Available CPU options support up to 400, 2,000 or 15,000 function blocks
- Simply drag and drop, and soft-wire
- 1oo2 and 2oo3 Voting Function Blocks. DO-V and AO-V (Digital Output and Analog Output Validation Function blocks).

Separate Process Safety Worksheets

- Same type of controller can be used for process and safety applications thus reducing total cost of ownership
- Provisions are provided within programming environment to program using safety/process worksheets

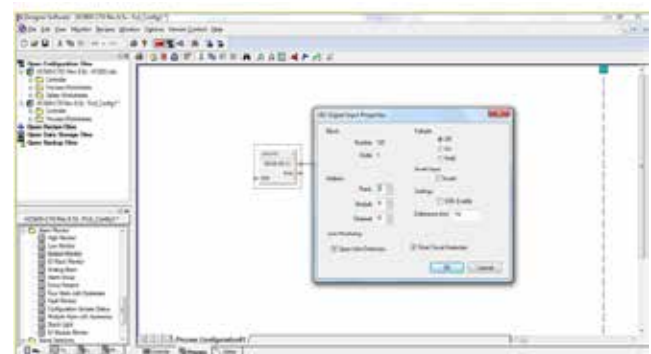

Universal Analog Inputs

- Accept both direct and indirect inputs from sensors
- Minimize the number of input cards and spare parts required
- Inputs may be mixed on a module and may include multiple thermocouple types, RTDs, ohms, voltage or millivoltage types.

SIL Universal IO Module

- 16 channel user configurable to DI, DO, AI or AO
- High resolution SOE with 1 ms time stamp
- Line Monitoring (Open Wire, Short Circuit Detection)
- In-built Voting & Validation

Control Loops

- Provide tighter, more accurate process control
- Include applications ranging from single loop control to interactive cascade, ratio, duplex, feed-forward, three-position-step, or custom controlled strategies
- Increase throughput, reduce scrap, and minimize energy costs
- Quantity of loops per controller is not limited

Cascade control

- The Cascade Loop uses 2 PID block with the back calculation pin of the secondary (BCD) connected to the primary loop (BCI). This transfers values back to the primary loop to adjust the PID for changes in mode of the secondary loop
- The RSP input for the secondary loop can be selected to be in engineering units or %, eliminating the need to scale the output of the primary loop

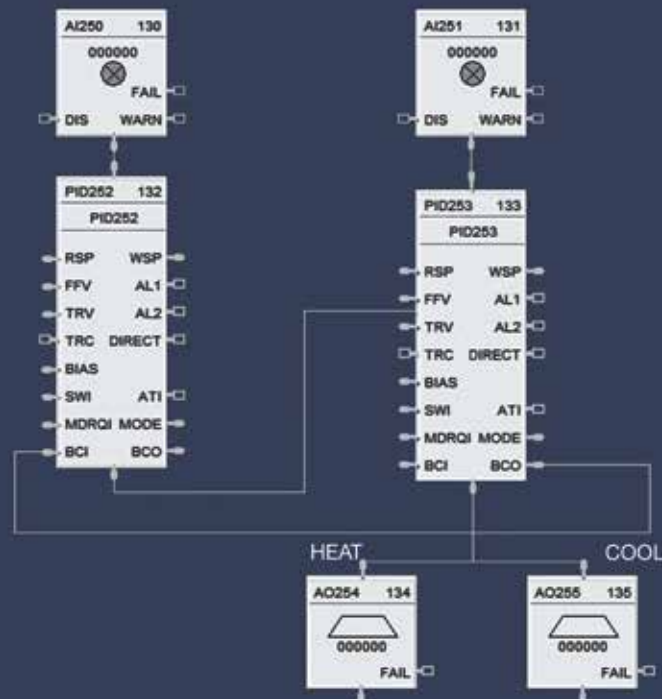

Accutune III

- Standard auto tuning on every control loop
- Reduces start-up time
- Ensures on-spec product

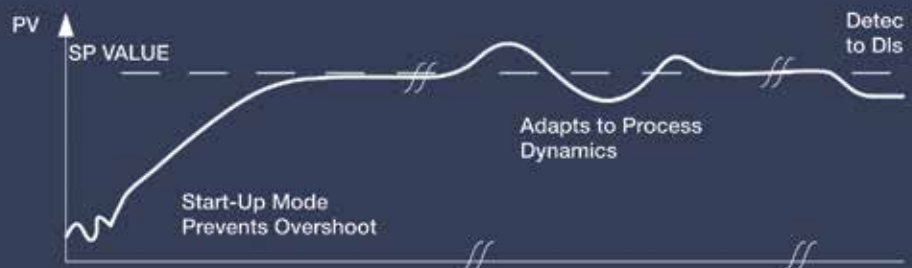



Fuzzy Overshoot Suppression

- Fuzzy Overshoot Suppression minimizes the Process Variable (PV) overshoot following a Setpoint (SP) change or a process disturbance. This is especially useful in processes that experience load changes or where even a small overshoot beyond the setpoint may result in damage or product loss.
- The Fuzzy Logic in the controller observes the speed and direction of the PV signal as it approaches the setpoint and temporarily modifies the internal controller response action as necessary to avoid an overshoot. There is no change to the PID algorithm, and the Fuzzy Logic does not alter the PID tuning parameters.

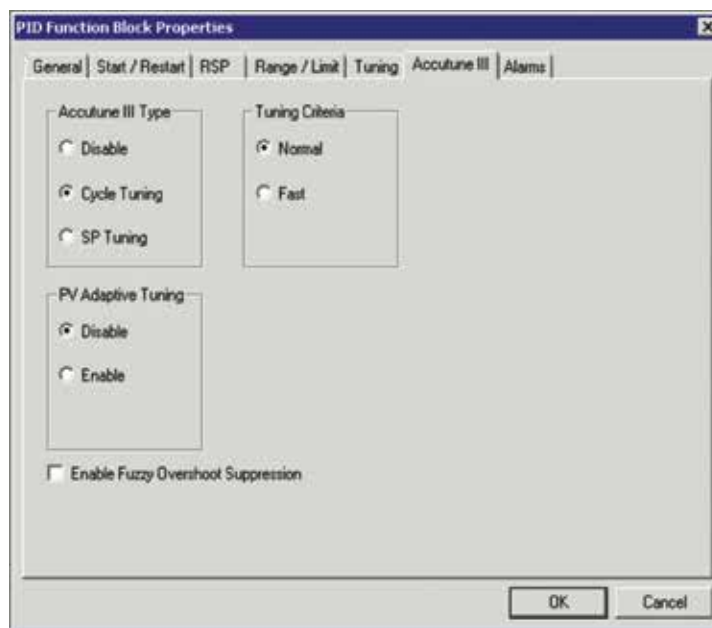

Carbon Potential

- The carbon potential of the furnace atmosphere can be controlled by monitoring the furnace temperature and the probe output because oxygen potential directly relates to the carbon potential. A combined carbon probe, temperature probe and PID algorithm determine carbon potential of furnace atmospheres based on a zirconium probe input.
- Activates anti-sooting feature that limits the working setpoint of the carbon control loop to a value that prevents sooting in the furnace.

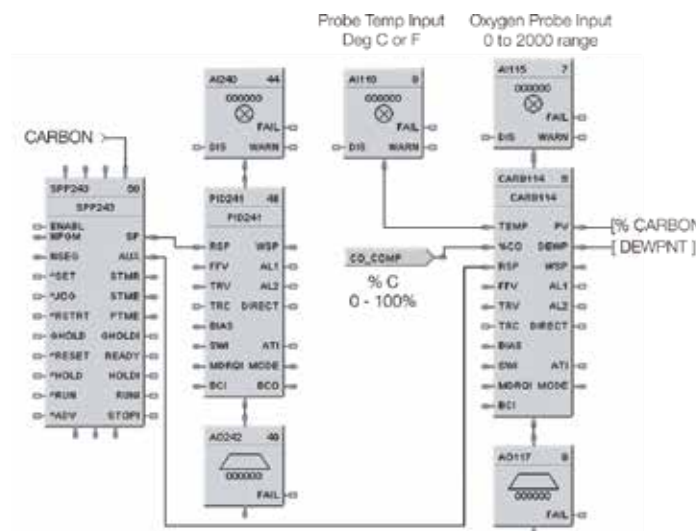



Free-format Logic

- Optimizes design by combining multiple logic functions into one
- Simplifies operation and troubleshooting

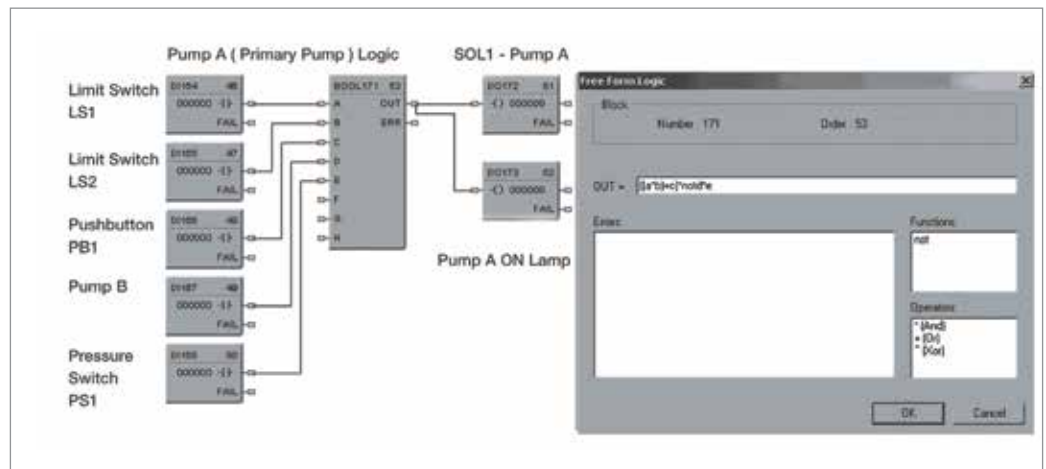

Sequencers

- Control the output states of multiple digital parameters
- Control the sequence of process operation based on time or process events
- Each sequencer supports up to 16 digital outputs and may have up to 50 process states
- Multiple sequences can be selected on demand from the operator interface or as part of a recipe

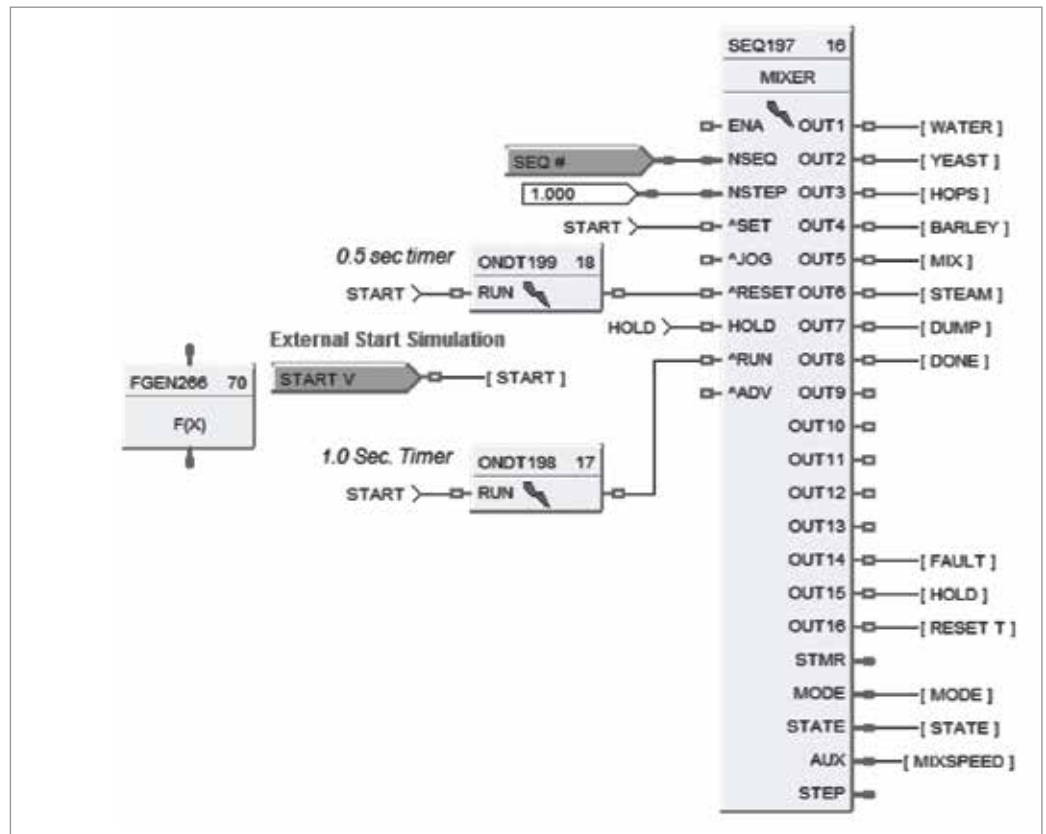



Recipes

- Stored in the controller memory
- Ensure error-free product/ process changeovers
- Write values into analog and digital variables
- Load via Control Station
- Load via RCP block
- Can be used to:
 - Write a value to any variable
 - Load setpoints
 - Select setpoint programs
 - Set alarm limits
 - Activate control valves



Setpoint Programmer

- Automatically manipulates a setpoint value for use by PID loops
- Creates a time / value profile for process batch control
- Multiple setpoint programmers, with profiles of up to 50 segments each, may be configured and stored
- Any programmer may run any profile separately or simultaneously
- Each also has an auxiliary soak output and up to 16 event outputs for integration with sequence control functions

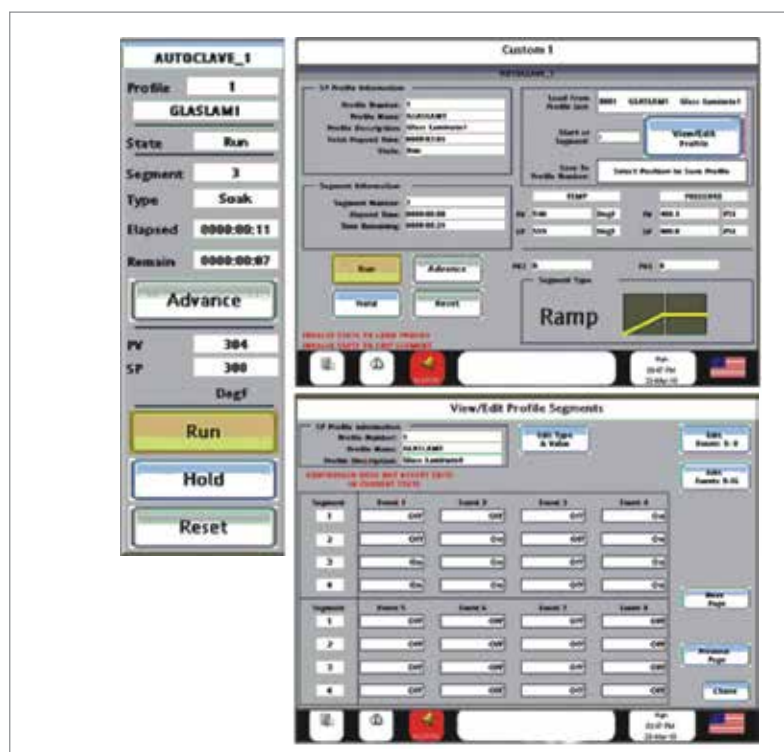



Dew Point Control

- Dew point analysis measures the amount of water vapor present which in turn helps determine the carbon potential of a furnace atmosphere
- This application uses the dew point function block to calculate dew point based on using a carbon probe where the input is an O2 sensor
- A typical example is control of an endothermic atmosphere generator when the user requires dew point for PV

Dewpoint Calculation ✖

Furnace Properties:		Block 283	<input type="button" value="OK"/>
Furnace Factor: 0		Order 137	<input type="button" value="Cancel"/>
Use Anti-soot Constant: <input type="checkbox"/>		CO Properties	
Low Temperature Limit: 0		% CO: 20	
Celsius <input type="radio"/> Fahrenheit <input checked="" type="radio"/>		Use Actual % CO: <input type="checkbox"/>	
Percent Hydrogen: 40		O2 Probe Manufacturer	
		<div style="border: 1px solid gray; padding: 2px;"> Unknown Unknown Advanced Atmosphere Control Corp. Furnace Control Corp. Marathon Monitors Super Systems Inc. </div>	

Setpoint Scheduler

- Provides up to eight ramp/soak setpoints that operate on a common time base
- Supports up to 16 event digital outputs 50 segments per schedule; the number of stored schedules is configurable
- Auxiliary Scheduler provides an additional 8 Soak Setpoints
- Multiple independent setpoint schedulers are available in a configuration

SPS105		1
SPS105		
ENABL	NPGM	STMR
NSEG		STME
^SET		PTME
PV1		SP1
PV2		SP2
PV3		SP3
PV4		SP4
PV5		SP5
PV6		SP6
PV7		SP7
PV8		SP8
STRQ		STFL





Redundancy

- Maximize process availability by providing backup controllers, power supplies and communications for seamless failover under fault conditions
- Redundant Switch Module (RSM) is located in the rack between two CPUs and visually indicates which CPU is the lead and which is the reserve
- Key switch on the RSM allows the user to change the operating mode of the lead and reserve CPUs
- Ethernet network ports are continuously active on the lead controller, each on a different subnet
- Transfer of communications from one port to another port on the same CPU is handled by the host application
- A secondary power supply can also be added to each ControlEdge 900 Platform I/O rack for standby redundancy

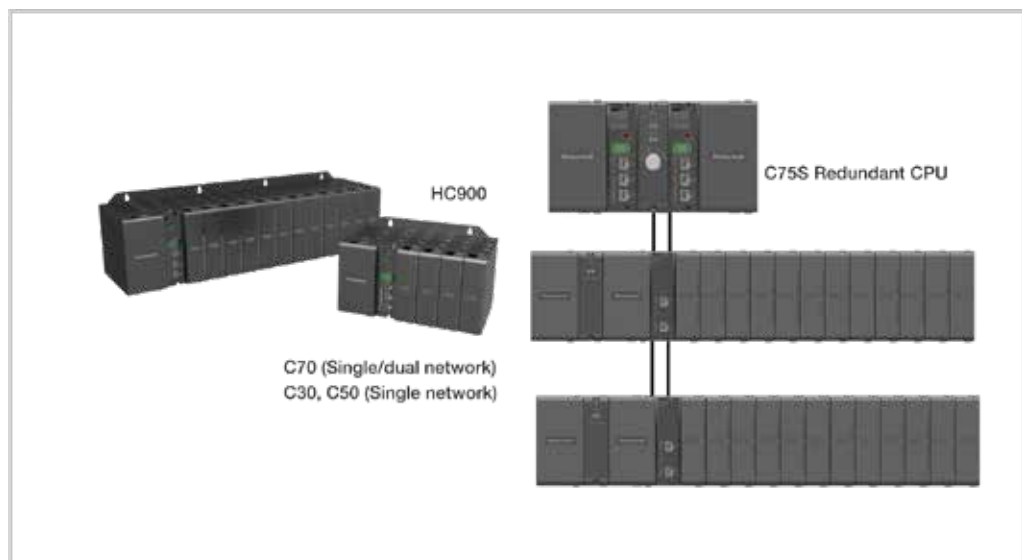

AMS Compliance

- The ControlEdge HC900 meets AMS 2750E, the key requirement for controlling, monitoring and recording instruments, which is a calibrated accuracy ($\pm 2^\circ \text{F}/1.1^\circ \text{C}$)

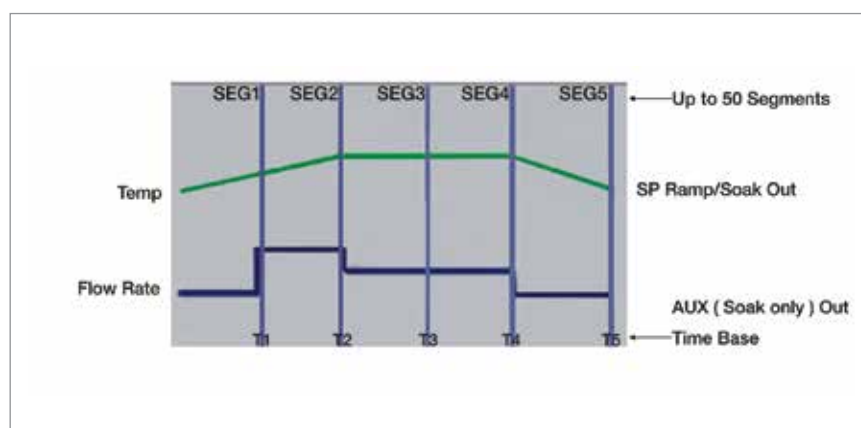

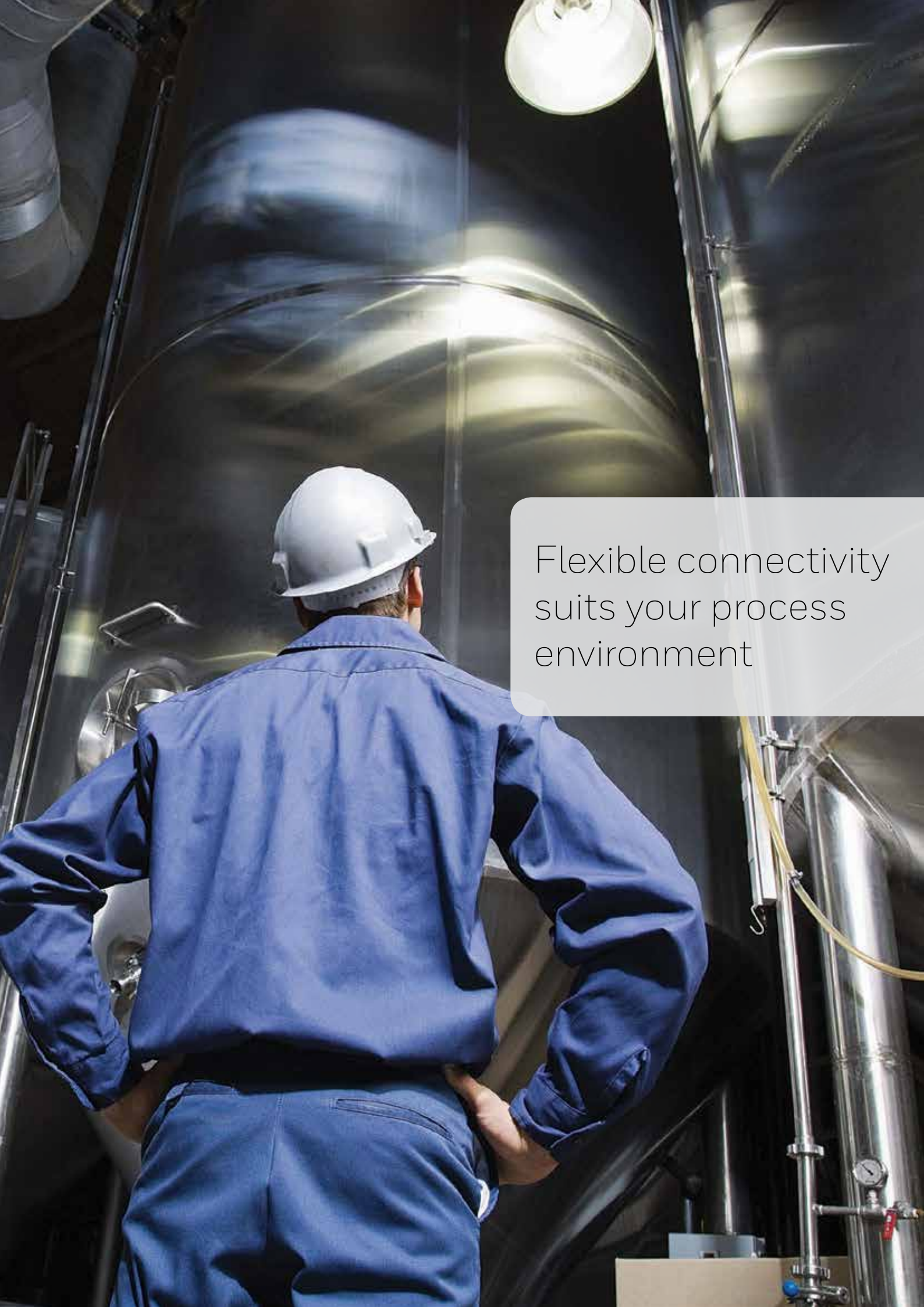

Flexible connectivity
suits your process
environment



Open Ethernet Connectivity

- Enables ControlEdge HC900 controllers to communicate with their host interfaces and each other
- Open Modbus / TCP protocol allows interfacing to most popular HMI, data acquisition and OPC software
- Up to 10 device connections are supported on the host Ethernet port
- ControlEdge HC900 network of controllers and operator interfaces are partitioned into segments on the network to maximize communication performance

Serial Ethernet Connectivity

- Allows two RS485 ports to be configured as Modbus slaves, while one of the ports is selected as a Modbus master
- Wide variety of devices (touch panel operator interfaces, I/O devices, etc.) can be connected to the controller
- Provides greater flexibility in system design

Connectivity and Communications

- Adapts to existing process-line infrastructure
- Satisfies specific control requirements
- Accommodates specialty applications

Peer-to-peer Communications

- The improved ControlEdge HC900 controllers provide peer-to-peer interface between a maximum of 32 units for process/safety equipment applications that require sharing data between controllers.
- Up to 2,240 parameters per controller may be exchanged
- Standard Ethernet communication port supports concurrent peer-to-peer communications and connectivity to supervisory systems
- Peer-peer between safety systems is done using the new Safety-peer protocol that can exchange safety critical data between peers

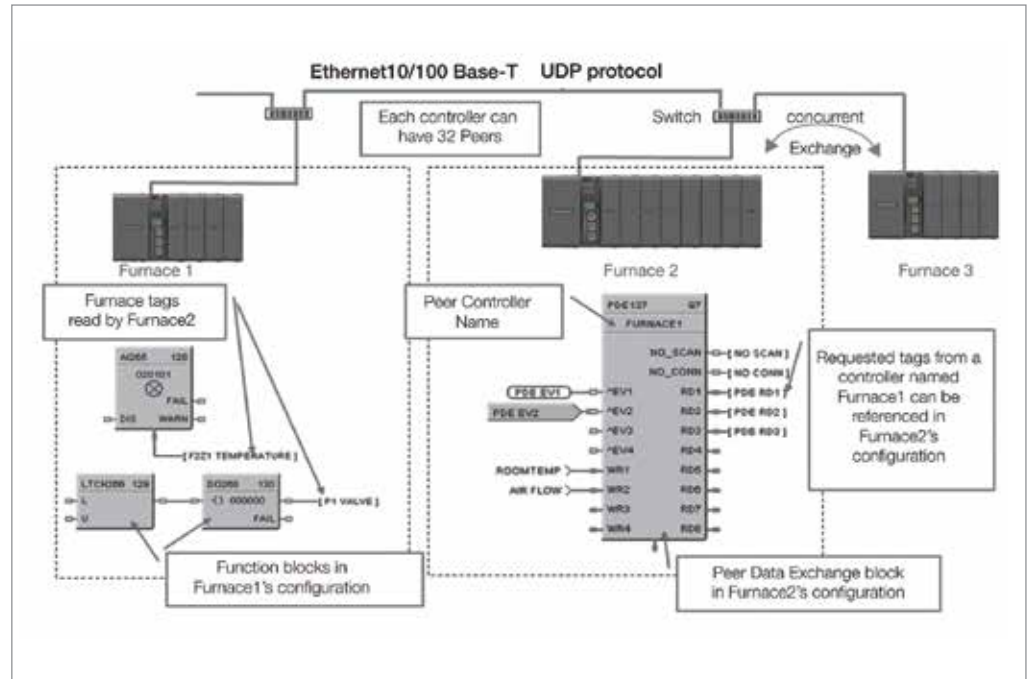

Integration with Experion

- ControlEdge HC900 controllers can be integrated with the Honeywell Experion DCS system for supervisory control and data acquisition
- Can be integrated with Experion PKS, LX and HS systems Configured using Quick Builder application
- Uses Universal Modbus Driver for communication
- Redundant controllers can also be integrated with Experion
- History Backfill: If Experion HS loses communication with ControlEdge HC900 the History backfill functionality will backfill data to the HMI once communication is restored. This feature is very important for food and beverage, pharmaceutical and other data critical applications and is not often provided by other general purpose PLC's
- Paired with Experion HS, ControlEdge HC900 can meet FDA 21 CFR part 11 requirements for pharmaceuticals, food and beverage industry that need a proven and reliable solution capable of change management, automated electronic record keeping, and advanced controller security and protection methods

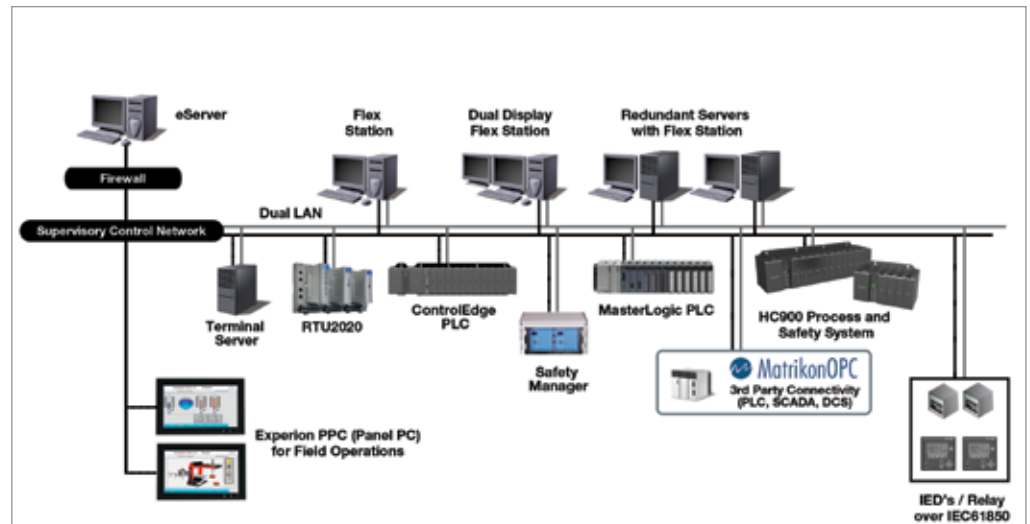

ControlEdge HC900 OPC Server from MatrikonOPC

- Provides secure and reliable real-time data access between the ControlEdge HC900 Controller and any OPC-enabled applications such as Historians, HMIs, SCADA etc.
- Enables 3rd party connectivity for successful phased migration and integration
- Enables easy and cost-efficient management of openly connected systems



Building-block configuration simplifies control implementation



ControlEdge HC900 Designer Software

- Enables system configuration with a Windows 7 (32 or 64-bit), Win 8 and Win 10 based PC
- English and Mandarin languages supported (switchable after installation)
- Uses drag-and-drop placement techniques for graphic icons and soft-wiring connections between function blocks
- Automatically calculates memory usage and processor scan time as function blocks are configured
- User-friendly graphic development allows partitioning of the control strategy into multiple worksheets

- Ease of record-keeping, faster access to functional areas during programming
- Better support for user-specified process function identifications

Configuration Debug Tools

- Simplify troubleshooting Include online monitoring of multiple function blocks on a single display, on/off identification of digital signal flow connections, and output forcing capability for most block outputs
- Selectable user-defined Watch Windows and Signal Trace-back provide a clear view of the configuration operation and quick identification of potential errors

Printable Presentation Formats

- Simplify configuration documentation
- Include a summary of controller I/O, the graphic configuration diagram, function block properties, recipe groups, setpoint profile groups, operator display and point selection

Run-mode Configuration Editing

- Standard feature that can significantly reduce start-up time and avoid costly process shutdowns

System configuration and operation adapt to your needs



Standard displays provided in ControlEdge HC900 Control Station

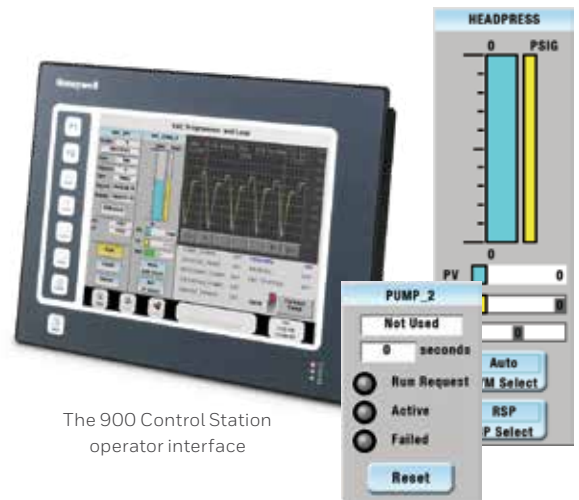

The 900 Control Station operator interface

Operator Interface features

- NEMA Type 4X operator interface screen withstands harsh operating environments
- Easy-to-operate 10"-display includes both a touch screen and dedicated buttons
- Standard and custom graphic elements can be assembled into specific displays, for fast and easy start-up
- Custom graphics tools let you select from 4,000+ pre-built objects for animation support, math, formulas, scripting
- Function block widgets accelerate configuration development
- Controller status displays verify system integrity, with no configuration required
- Recipe selection makes product/process changeovers simple and accurate
- Trending and data logging is provided via non-volatile flash card storage, with USB memory support and no artificial limits
- Multi-level log-on security feature prevents unauthorized access
- Alarm/Event logging with e-mail notification of impending problems tracks process upsets and validates performance
- Ethernet or serial connectivity enhance installation flexibility, includes Modbus and Modbus/TCP protocol support
- Embedded web server feature allows access to your application from anywhere
- Multiple interfaces on each controller enable process management from up to three locations
- Multilingual: English, French, Italian, German, Spanish. Other languages may be added by expanding its lexicon library
- The software also supports accessing the translation libraries of Microsoft® and / or Google® for any untranslatable text strings used in the product during configuration
- Setpoint Programmer Pre-Plot Display: Pre-plot display is a Widget that gets bound to a Setpoint Programmer function block
- Concurrent Batch Reports: Schedules multiple batch reports to run concurrently
- Bar Code/Keyboard Input: Use touch screen, remote keyboard or barcode reader to enter data
- GSM/GPRS, SMS Available: The GSM/GPRS modem may be used via a Cellular Network Provider's wireless network
- Emulation: Launch the emulator to see data as it would appear on the operator interface

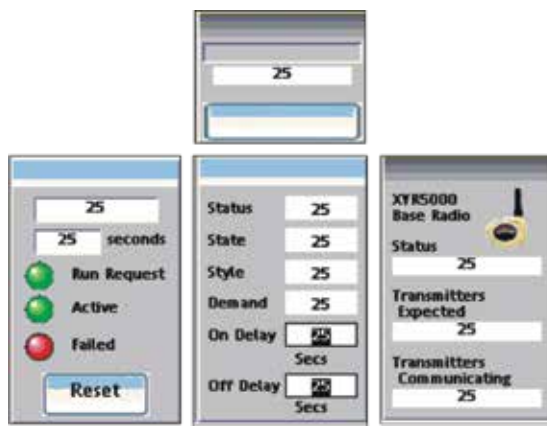

Standard displays in station designer 4 - Widgets

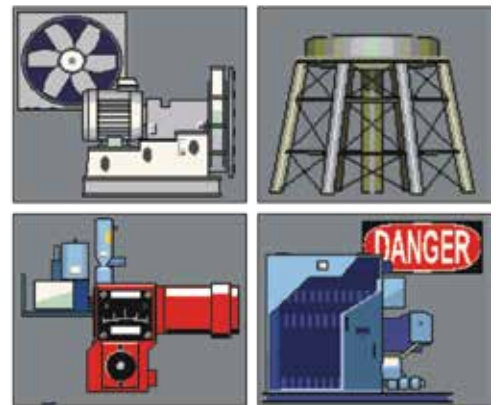

Graphic symbols provided in Station Designer software to simplify configuration. Hundreds of icons available including pumps, valves, and tanks icons shown.

Control Station Operator Interface

- The 900 Control Station is available with either a 10.4 inch (254 mm) or 15 inch (381mm) display size
- LCD Display: 10 inch 640 X 480 15 inch 1024 x 768 pixels, color active matrix thin film transistor (TFT), 32,000 colors
- Touch Screen: Resistive analog
- Backlight: 50,000 hr typical lifetime at room temperature (field replaceable in non-hazardous locations)
- Distance from Controller: Ethernet-328 ft (100 m), RS485 - 2000ft (600 m) RS232 - 50ft (15.24 m)
- Power Supply 10 inch: 24 Vdc, 29 Watts maximum 15 inch 46 Watts maximum without options
- Operating Temperature: 32 to 122 °F, (0 to 50 °C)
- Humidity: Rated 10 to 80%, non-condensing from 32 to 122 °F, (0 to 50 °C)
- Panel Rating: Type 4X
- Memory: 32 MB onboard non-volatile flash, optional memory card (compact flash 2 GB)
- Communication Ports: 10 inch (254 mm) 1 x Ethernet RJ45 10/100 base T, 15 inch (381mm) 2 x Ethernet 10/100 base T, 1 x RS-485, 2 x RS232 Serial
- USB Ports: 2 x USB specification 2.0 host port, type A, 1 x USB specification 2.0 device port type B

900 Station Designer Software

- Configuration: 900 control station CS interface – offline
- Operating environment: Windows 7 (32, 64-bit), Windows 8, Windows 10
- PC: Pentium class processor and RAM as required by the chosen operating system plus 50MB for software installation, 800 by 600 pixels minimum, 256 or more colors. RS-232 or USB port
- Cable: USB Host, RS232 Serial, Ethernet 10/100 base T

Easy engineering and
flexibility through user
friendly tools





Bulk Edit

- Reduces engineering hours

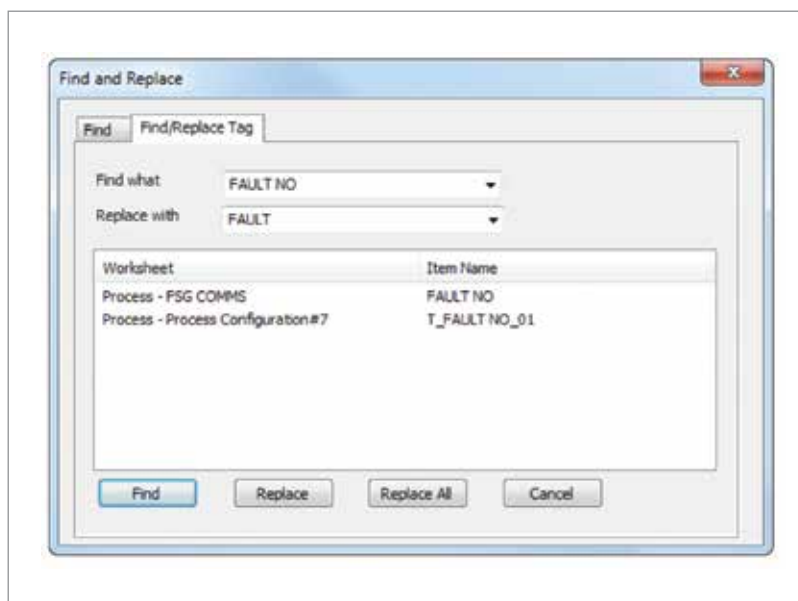

Configuration Comparison

- Change management
- Save engineering hours in finding previous changes

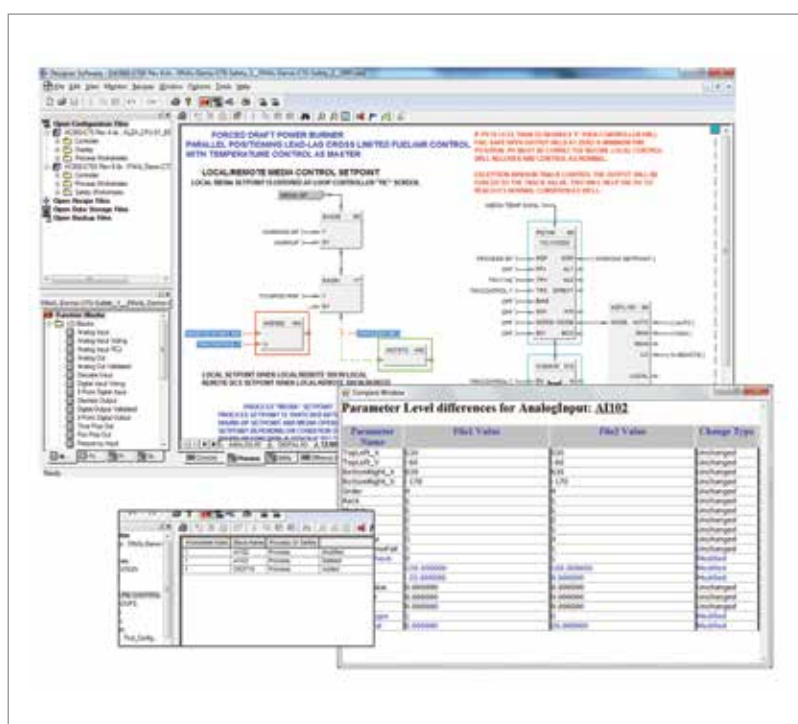



Version Control

- Easy tracking, de-bugging
- Revert to earlier versions
- Save dollars for a separate version control offering

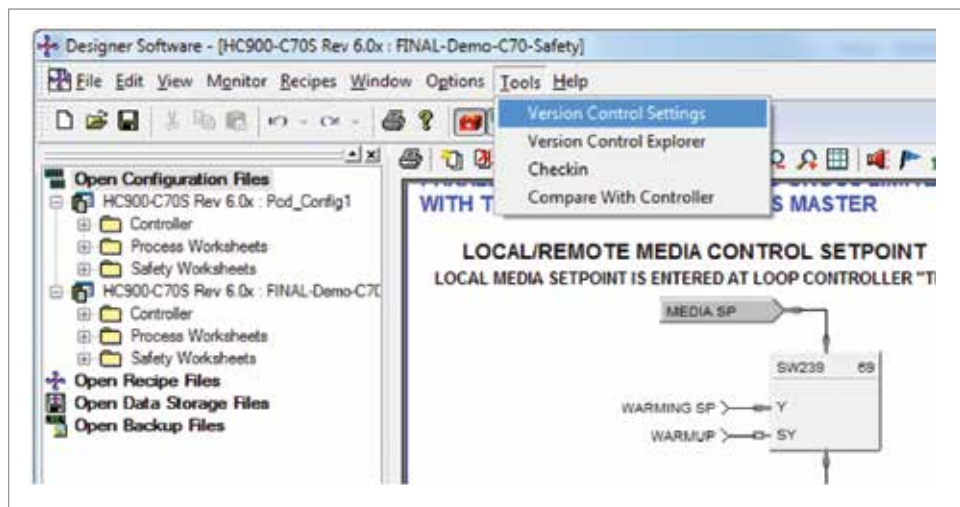

Paste Special

- Saves 15-20% of engineering efforts

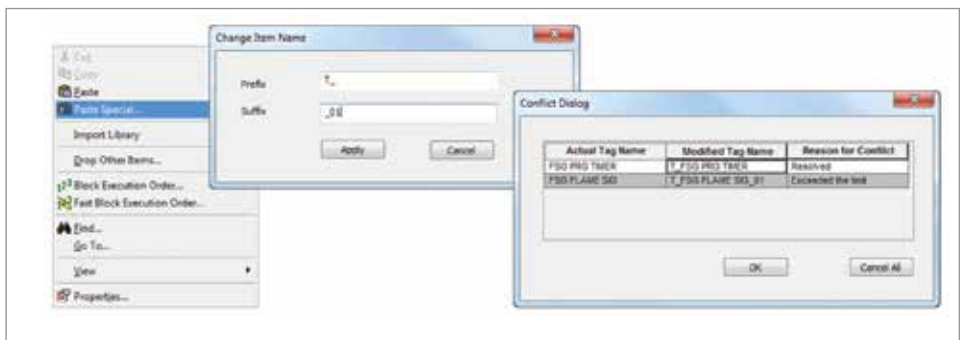

Change Management

- Manage versions, track and compare configurations
- Easier troubleshooting thereby reducing maintenance costs

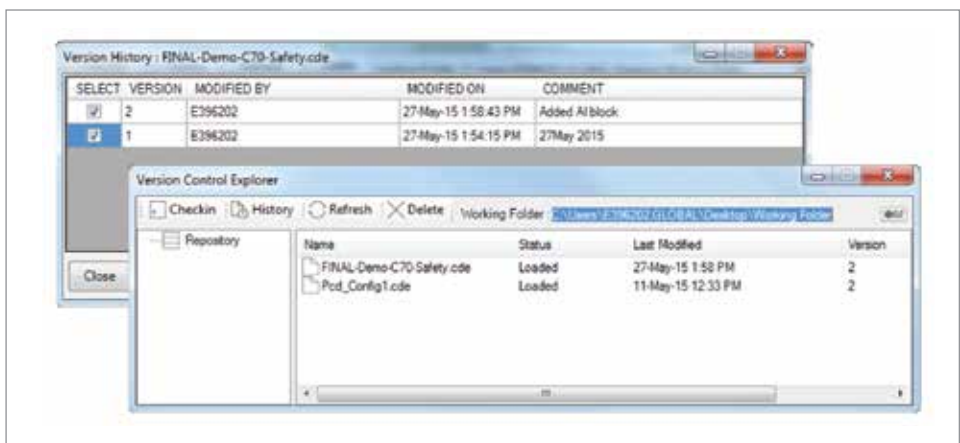

Re-usable Custom Libraries

- Save engineering time, create logic once and avoid errors

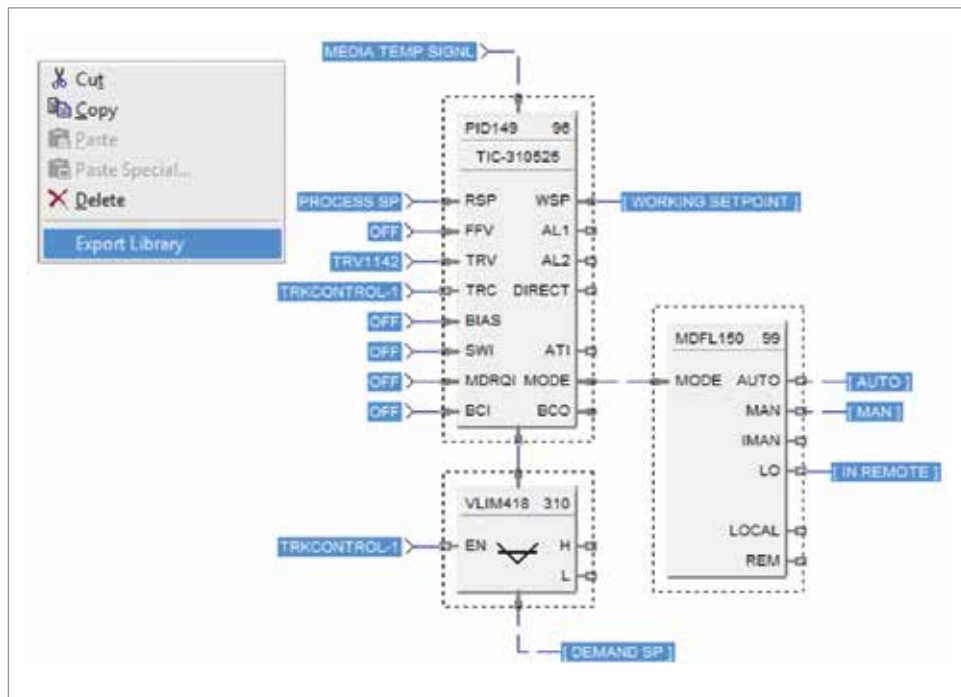

Password protection

- Controllers are password protected and thus prevents any intrusion through the network
- Any changes to the controller are monitored and validated with credentials



For more information

To learn more about Honeywell's Control Edge HC900,
visit www.honeywellprocess.com
or contact your Honeywell account manager.

Honeywell Process Solutions

1250 West Sam Houston Parkway
SouthHouston, TX 77042

Honeywell House, Skimped Hill Lane Bracknell,
Berkshire, England RG12 1EB UK

Building #1, 555 Huanke Road,
Zhangjiang Hi-Tech Industrial Park,
Pudong New Area, Shanghai 201203

www.honeywellprocess.com

Experion® is a registered trademark
of Honeywell International Inc.
All other trademarks are the property
of their respective owners.

BR-13-03-ENG | 04/18
© 2018 Honeywell International Inc.

Honeywell